

DC POWERED HYDRAULIC SCISSOR LIFT TABLE -SCTAB-2000-3240-DC

APPROX WEIGHT: 361.07 lbs. DOES NOT INCLUDE WEIGHT OF POWER OR PACKAGING!!!

*** ANY ADDITIONS, DELETIONS, OR OMISSIONS MUST BE CORRECTED ON THIS DRAWING AS THIS DRAWING WILL BE CONSIDERED ALL INCLUSIVE ***
 ALL GRAPHICS PROVIDED ARE FOR REFERENCE ONLY. IF CERTAIN DIMENSIONS ARE CRITICAL PLEASE VERIFY THOSE DIMENSIONS WITH YOUR SALESPERSON

DECK TOLERANCE ± 1/2"
 TABLE HEIGHT TOLERANCES ± 1/2"
 DECK FLATNESS ± 1/4"

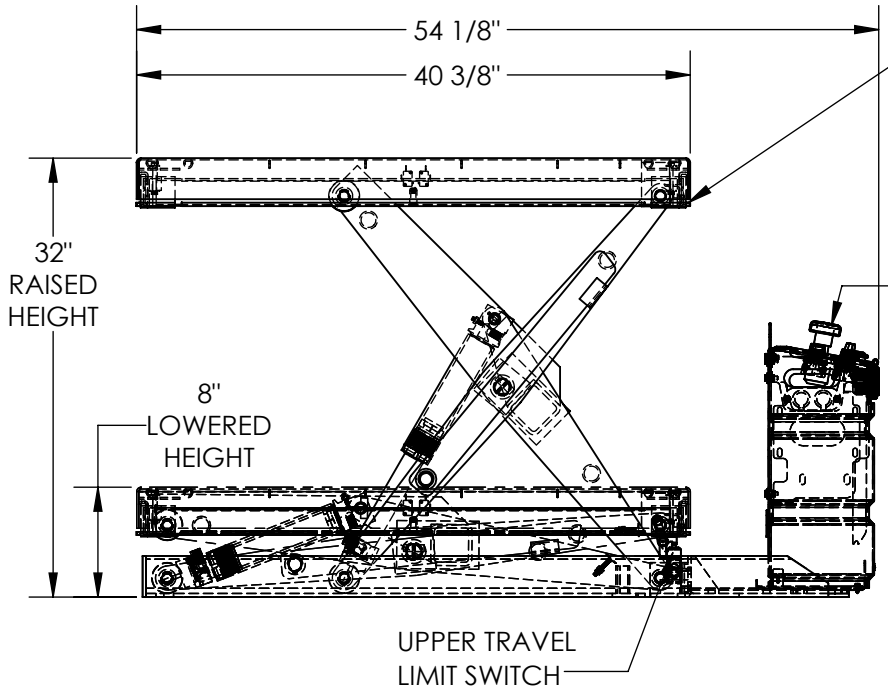

ELECTRIC TOEGUARDS
 (STOP TABLE FROM
 LOWERING IF BUMPED)
 MEETS OSHA 1910.212

STANDARD:
 12V DC HYDRAULIC POWER UNIT
 RAISED AND LOWERED BUTTONS
 ARE ON TOP OF POWER UNIT
 WITH ON BOARD CHARGER
 AND HAND CONTROL

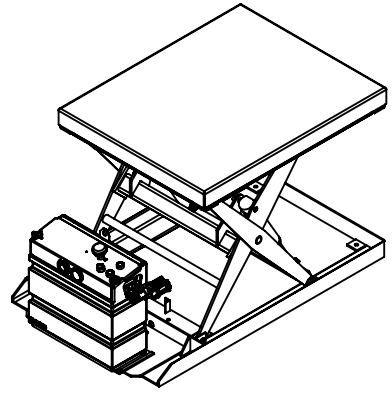
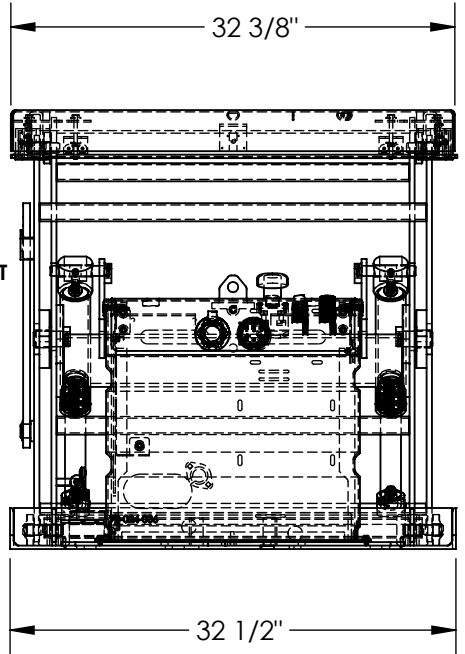

STANDARD FEATURES

- MODEL NUMBER IS SCTAB-2000-3240-DC
- DECK WIDTH IS 32 3/8"
- DECK LENGTH IS 40 3/8"
- RAISED HEIGHT IS 32"
- LOWERED HEIGHT IS 8"
- TABLE CAPACITY (EVENLY DISTRIBUTED)
- MAX CAPACITY IS 2,000 LBS
- CONTROL IS HANDHELD 2 BUTTON, NEMA 4 PENDANT WITH MINIMUM 8' USABLE COIL CORD
- SAFETY MAINTENANCE PROPS, DISPLACEMENT STYLE CYLINDERS INSTALLED ROD DOWN
- EMERGENCY SAFETY STOP HYDRAULIC FUSES
- UPPER TRAVEL LIMIT SWITCH
- ELECTRIC PINCH POINT GUARD
- DURABLE LIQUID PAINT BLUE FINISH

SPECIAL FEATURES

NONE

DIMENSION TOLERANCE ± 1/4"

APPROVAL	I, THE UNDERSIGNED, AGREE THAT THE PRODUCT AS REPRESENTED SATISFIES DESIGN AND DIMENSION REQUIREMENTS. I ALSO ACKNOWLEDGE MY DUTY TO CONFIRM PRODUCT AND INSTALLATION COMPLIANCE WITH ALL APPLICABLE FEDERAL, STATE AND LOCAL REGULATIONS AND STANDARDS.	
	ANY MODIFIED UNITS ARE NON-RETURNABLE	
	[] As drawn	[] As marked
Signed: _____		Date: _____
Printed Name: _____		
<i>LEAD TIME WILL START UPON RECEIPT OF SIGNED APPROVAL DRAWING</i>		

FOR INTERNAL USE ONLY PROJECT SIGN OFF	
SALES	
ENG.	
FAB.	
POWER	

DISTRIBUTOR'S NAME:		P.O.#
VESTIL MANUFACTURING		X
DRAWN BY: CRA		W.O.#
DATE: 10/13/2017		X
REFERENCE: X	SCALE: 1:14	SALES: X
QUOTED LEAD TIME: X	QUOTE #	FILE NAME:
	X	01-007-367